

NORSTEEL Portable Truck Scale



- **Long Life Heavy Duty Construction**
- **Light Weight, Easy to Load**
- **Legal-for-Trade**

NORSTEEL Portable Truck Scale

NORAC's portable truck scales are built with strength, convenience, and versatility in mind. All NORAC scales are designed for longevity. Our NORSTEEL Portable Truck Scales are no exception.

Easy to Use Versatility

Our scales are shipped completely preassembled with all components protected within a rugged frame.



The decks are stackable and lightweight to load - making them easy to transfer to multiple locations.

This unique design of lightweight durability also permits lengthening the scale to be manufactured to a maximum length of 120 feet.

All NORSTEEL Truck Scales are designed for above the ground installation. No costly pits are required.



NORAC's portable truck scales require some simple levelling with timbers at each load cell location and at each end of the scale.

Spend less time building long approach ramps; once in place the NORSTEEL Portable Truck Scale has an overall height of merely fourteen inches.

Durability

NORAC uses only heavy-duty tubular steel in the construction of the NORSTEEL Portable Truck

Scale. Load bars on our portable truck scales are meticulously constructed of rugged steel with precision bearing components balanced and calibrated at the factory for years of worry free performance.

Special rust-prohibitive paint protects all NORSTEEL truck scales from the harshest environmental conditions.

Our scales are known to handle loads well above their rated capacity and will take the years punishment that a portable truck scale must endure.



Measurement Canada Approved

All NORSTEEL Portable Truck Scales can be Pre-Approved as "legal-for-trade" at the time of purchase. By permitting Measurement Canada to certify the scale at our plant prior to delivery you avoid a costly on-site inspection.

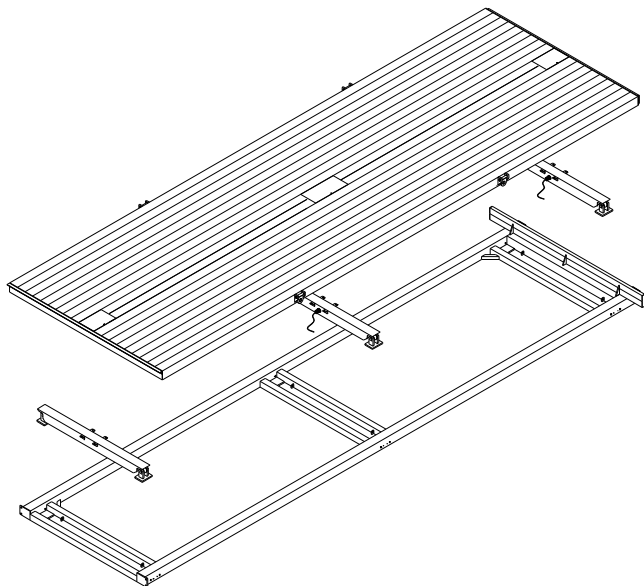

- Lightweight - Easy to Load
- Stackable for Transport
- Heavy Tubular Steel Construction
- Sandblasted and Epoxy Primed Urethane Coated for Long Life
- "Legal-For-Trade"

NORAC SYSTEMS INTERNATIONAL INC.

HEAD OFFICE

803-46th Street E.
Saskatoon, SK S7K 0X1
CANADA

PH: (306) 664-6711
FX: (306) 664-6664
sales@norac.ca

UNITED STATES OFFICE

Suite 42, 1451 NE., 69 Place
Ankeny, IA 50021
UNITED STATES

PH: (515) 289-2906
FX: (515) 289-0057

EASTERN CANADA WAREHOUSE

105 Old Onondaga Rd. E.
Brantford, ON N3T 5L4
CANADA

NORAC 
WEIGHING AND CONTROL SYSTEMS
1-800-667-3921
www.norac.ca